

THIS DRAWING IS UNPUBLISHED. RELEASED FOR PUBLICATION, 19 .  
 © COPYRIGHT 19 BY AMP INCORPORATED. ALL INTERNATIONAL RIGHTS RESERVED.

LOC		DIST		REVISIONS				DATE	APPD
ZONE	LTR	DESCRIPTION		DATE	APPD				
G	14	P	F	G	ADDED 2-4 PER 063A-0037-02	04FEB02	JR/MS		

**METRIC**  
 DIMENSIONS LISTED IN mm [ INCHES ]

<b>AMP</b> WIRE RANGE	<b>UL</b> E13288 Listed
16-14 AWG SOLID OR STRANDED	NOT APPLICABLE
<b>SR</b> LR7189 Certified	<b>MILITARY P/N AND CLASS</b>
NOT APPLICABLE	NOT APPLICABLE

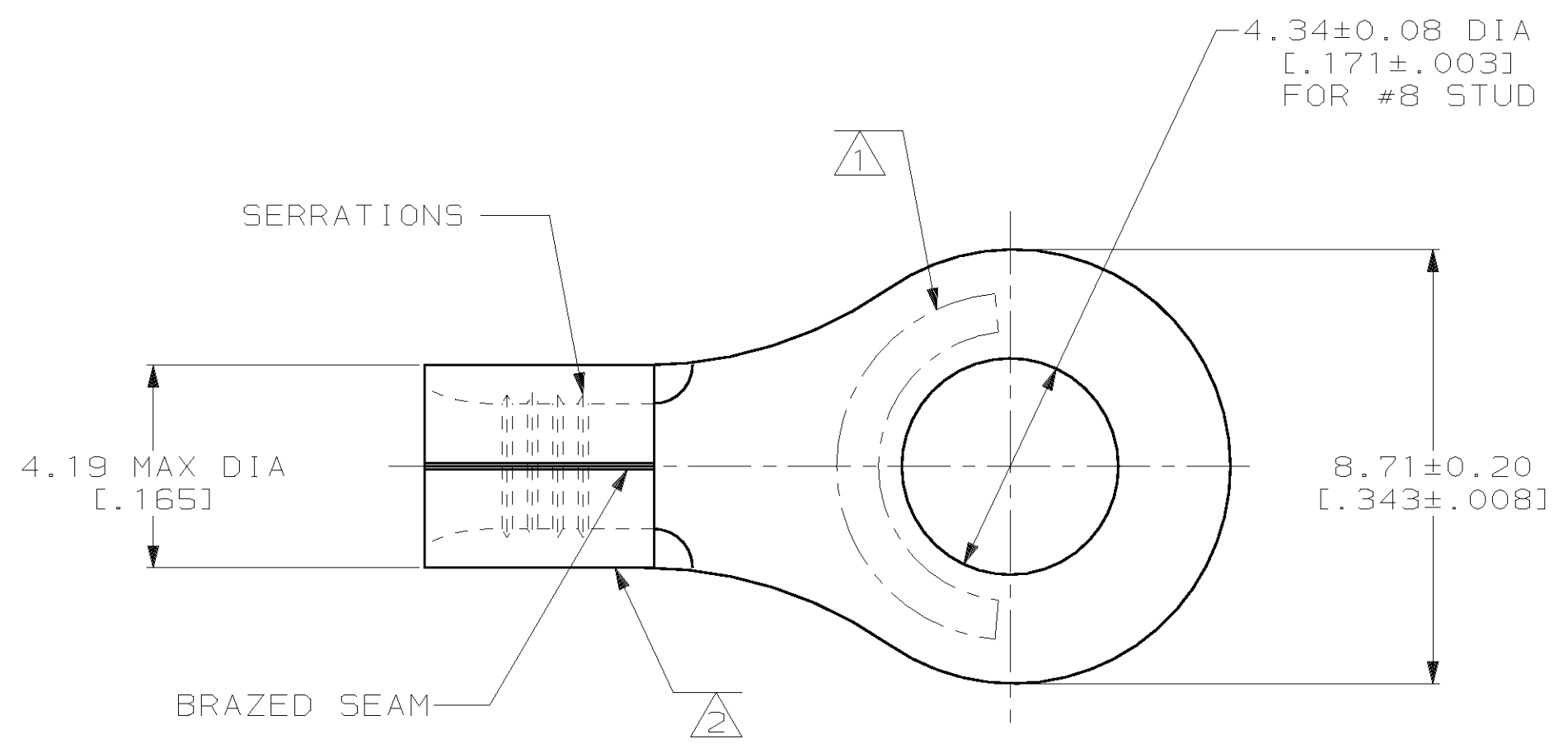

- ① STAMP AMP 16-14 APPROX AS SHOWN
- ② WIRE BARREL COLOR CODED ORANGE TO DENOTE NICKEL MATERIAL
- ③ PRE-PRODUCTION - FASR REQ

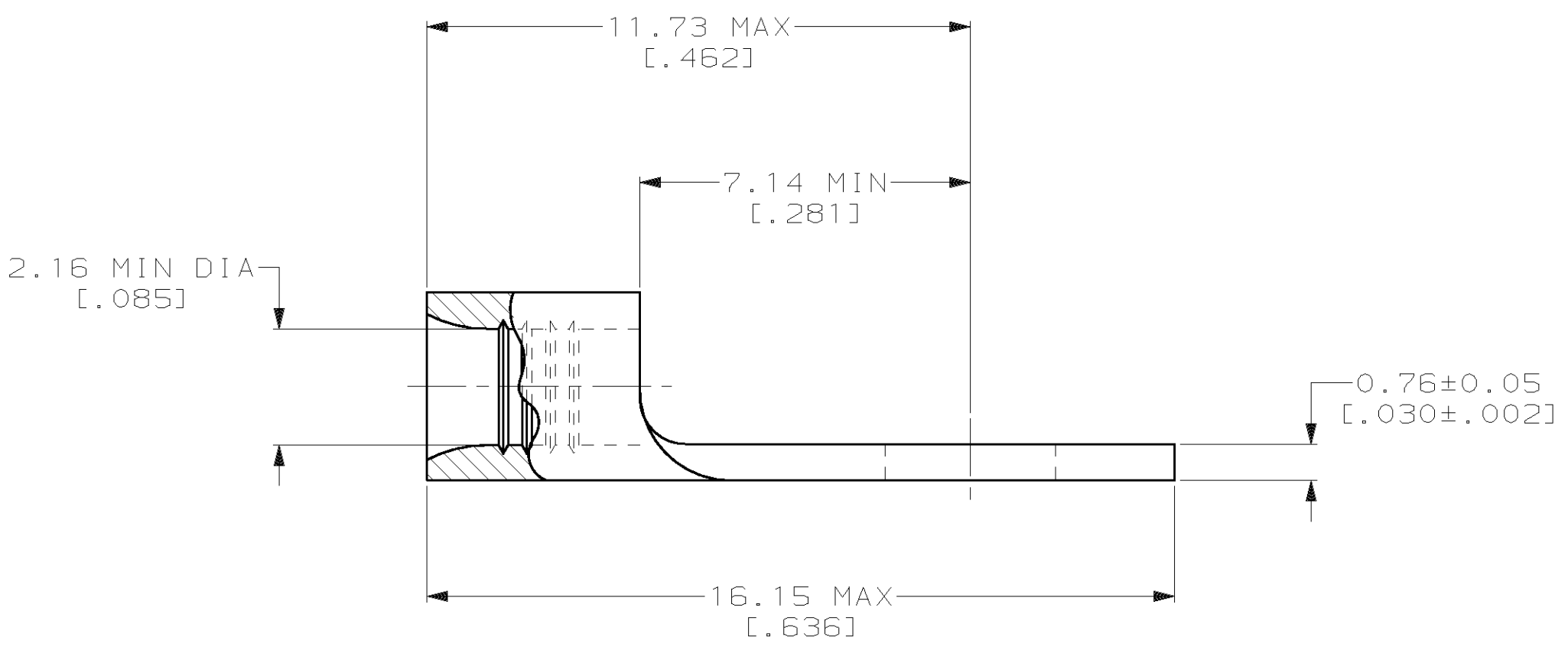

QUANTITY	PACKAGE TYPE	PART NO
100	LOOSE PIECE, BOX	8-322334-1
5,000	ON TAPE, REEL	③ 2-322334-4
----	LOOSE PIECE	322334

**AMP INCORPORATED**  
**CUSTOMER SERVICE SYSTEMS**

FOR ADDITIONAL PRODUCT INFORMATION OR COPIES OF DRAWINGS AND TECHNICAL DOCUMENTS  
 PRODUCT INFORMATION CENTER  
 1-800-522-6752

FOR APPLICATION TOOLING INFORMATION  
 TOOLING ASSISTANCE CENTER  
 1-800-722-1111

FOR ORDER ENTRY  
 1-800-526-5142

MAX RECOMMENDED OPERATING TEMPERATURE:  
 649°C MAX

VOLTAGE RATING:  
 NOT APPLICABLE

WIRE CROSS SECTIONAL AREA RANGE:  
 1.04-2.62mm<sup>2</sup> [2,050-5,180] CIR MILS  
 SOLID OR STRANDED

THIS DRAWING IS A CONTROLLED DOCUMENT FOR AMP INCORPORATED. IT IS SUBJECT TO CHANGE AND THE CONTROLLING ENGINEERING ORGANIZATION SHOULD BE CONTACTED FOR THE LATEST REVISION.

DO NOT SCALE PRINT. UNLESS SPECIFIED DIMENSIONS IN mm [INCHES]— TOLERANCES ON :  
 2 PLC DEC ± -  
 3 PLC DEC ± -  
 ANGLES ± -

MATERIAL  
 NICKEL PER ASTM B-162 ANNEALED

FINISH  
 -

DR 4-15-93 TA BRINKMAN  
 CHK 4-15-93 DA PATTERSON  
 APPD 4-15-93 DE MILLER  
 APPD 4-15-93 JL MECKLEY  
 PRODUCT SPEC -  
 APPLICATION SPEC -  
 WEIGHT -

**AMP** AMP Incorporated  
 Harrisburg, PA 17105-3608

NAME  
 TERMINAL, RING TONGUE,  
 HIGH TEMPERATURE,  
 STRATO-THERM

SIZE CAGE CODE DRAWING NO  
 C 00779 C=322334

SCALE 8:1 SHEET 1 OF 1